

# PRODUCT PRESENTATION

LUX LUX

S10

S11



LUX TOWER 



  
MADE IN  
ITALY

Made in Italy **certified and guaranteed.**

Lighting towers manufactured by **Luxtower** are designed and manufactured according to the quality standard of Made in Italy which guarantees reliability along with a unique style.

We are always looking for new market trends by offering solutions and innovative lines, with constant focus on **sustainability.**

# LUX S10



MADE IN  
ITALY

LUX  
S10

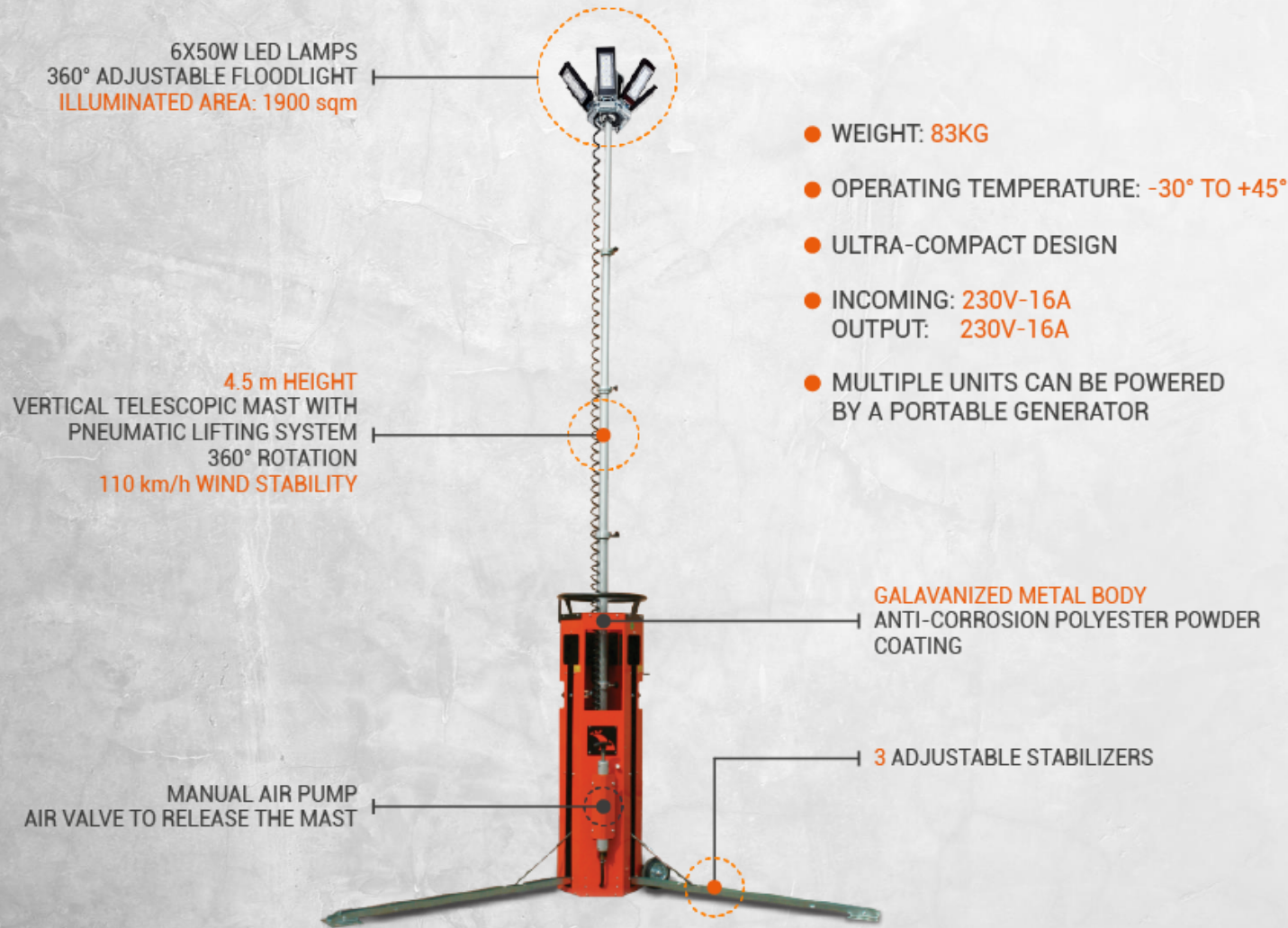

6X50W LED LAMPS  
360° ADJUSTABLE FLOODLIGHT  
ILLUMINATED AREA: 1900 sqm

4.5 m HEIGHT  
VERTICAL TELESCOPIC MAST WITH  
PNEUMATIC LIFTING SYSTEM  
360° ROTATION  
110 km/h WIND STABILITY

- WEIGHT: 83KG
- OPERATING TEMPERATURE: -30° TO +45°
- ULTRA-COMPACT DESIGN
- INCOMING: 230V-16A  
OUTPUT: 230V-16A
- MULTIPLE UNITS CAN BE POWERED  
BY A PORTABLE GENERATOR

GALVANIZED METAL BODY  
ANTI-CORROSION POLYESTER POWDER  
COATING

3 ADJUSTABLE STABILIZERS

MANUAL AIR PUMP  
AIR VALVE TO RELEASE THE MAST

MADE IN  
ITALY

LUX TOWER

[luxtower.com](http://luxtower.com)

# LUX S11



6X80W LED LAMPS  
360° ADJUSTABLE FLOODLIGHT  
ILLUMINATED AREA: 2900 sqm

4.5 m HEIGHT  
VERTICAL TELESCOPIC MAST WITH  
PNEUMATIC LIFTING SYSTEM  
360° ROTATION  
110 km/h WIND STABILITY

MANUAL AIR PUMP  
AIR VALVE TO RELEASE THE MAST

- WEIGHT: 84KG
- OPERATING TEMPERATURE: -30° TO +45°
- ULTRA-COMPACT DESIGN
- INCOMING: 230V-16A  
OUTPUT: 230V-16A
- MULTIPLE UNITS CAN BE POWERED  
BY A PORTABLE GENERATOR

GALVANIZED METAL BODY  
ANTI-CORROSION POLYESTER POWDER  
COATING

3 ADJUSTABLE STABILIZERS

MADE IN  
ITALY

LUX  
S11

MADE IN  
ITALY

LUX TOWER

[luxtower.com](http://luxtower.com)



**GALVANIZED  
METAL BODY  
WELL COVERED &  
PROTECTED**



**INLET AND  
OUTLET SOCKET  
230V/16A  
LAMP SWITCH  
WITH  
PROTECTION**



**LIFTING SYSTEM WITH  
PNEUMATIC AIR PUMP  
AIR VALVE TO PULL  
DOWN THE MAST**



SIZE  
FEELS



## FIRECO TELESCOPIC MAST

World leadership manufacturer of high quality aluminum telescopic masts

Mast equipped with O-RING with manual lock to avoid the collapse of the mast if stressed by strong vibrations



# LUX S10 led floodlight



**TEC-MAR®**  
High Lighting Performance



TEC-MAR s.r.l.  
Via delle industrie, 12  
26835 Crespianica (LO) Italy  
T. 0371.464029 F. 0371.484039  
[www.tec-mar.it](http://www.tec-mar.it)

MADE IN  
ITALY

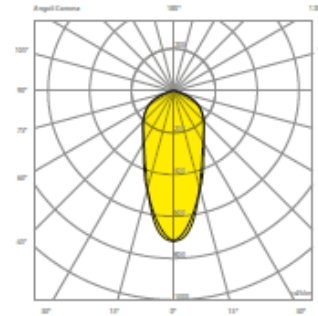

**KIT LINEA 6X50W – 5000K – OPTICS 30° CR**

**Grade of protection: IP65**

**Warranty: 5 years**

**Insulation class: 1**

**Nominal tension: 220-240V 50/60Hz**

**Temperature resistance: -25 / +45 °C**

**1900 sqm illuminated area**  
**5 Year warranty**



Singolo modulo

W-tot	°K	Lm [Tc=25°]	Lm [Output]	A	B	C	Kg	Lamp	Sost.
50	5000	8020	6416	93	230	20	1,0	1x12 led	500W ALO

\* Il flusso può variare da -5% / +5% comparato al reale

MADE IN  
ITALY

LUX TOWER

[luxtower.com](http://luxtower.com)

# LUX S11 led floodlight



**TEC-MAR®**  
High Lighting Performance

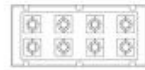

TEC-MAR s.r.l.  
Via delle industrie, 12  
26835 Crespiatica (LO) Italy  
T. 0371.464029 F. 0371.484039  
[www.tec-mar.it](http://www.tec-mar.it)

MADE IN  
ITALY



**KIT LINEA 6X80W – 5000K – OPTICS 30°CR**

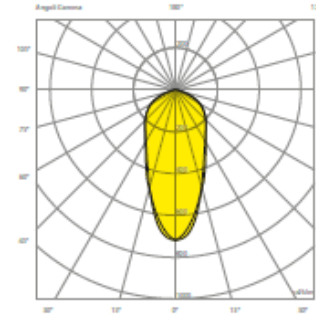

**Grade of protection: IP65**

**Warranty: 5 years**

**Insulation class: 1**

**Nominal tension: 220-240V 50/60Hz**

**Temperature resistance: -25 / +45 °C**

**2900 sqm illuminated area**  
**5 Year warranty**

Singolo modulo

W-tot	°K	Lm [Tc=25°]	Lm [Output]	A	B	C	Kg	Lamp	Sost.
80	5000	12306	9844	93	230	20	1,0	12x4 led	150W JM

\* Il flusso può variare da -5% / +5% comparato al reale

MADE IN  
ITALY

LUXTOWER

[luxtower.com](http://luxtower.com)



# LUX S10-S11 led floodlight



MADE IN  
ITALY



**GROUND LIGHTING  
OPTION**



**360° POSITION**



**180° POSITION**

MADE IN  
ITALY

LUXTOWER 

[luxtower.com](http://luxtower.com)



## ADJUSTABLE STABILIZERS TO REDUCE OVERALL DIMENSIONS

MADE IN  
ITALY



STABILIZER EXTENSION  
FROM 116 TO 73 cm

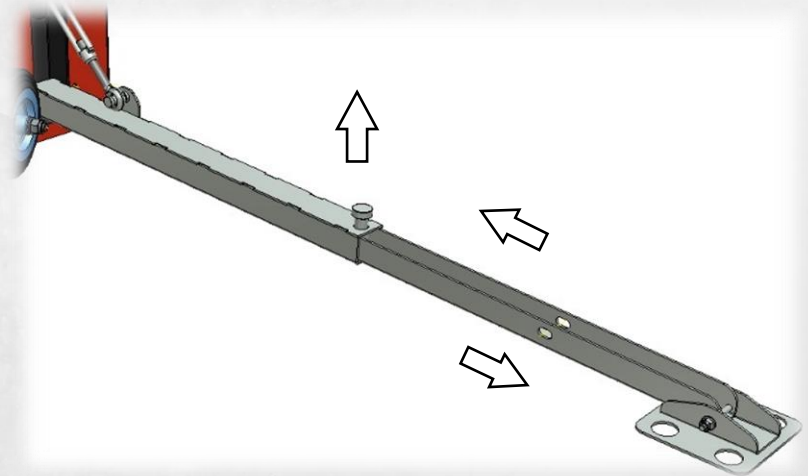

# LUX S10-S11 key benefits



MADE IN  
ITALY



**Additional wheel  
for simple horizontal  
handling**



**Wheels for handling**

MADE IN  
ITALY

LUX TOWER

[luxtower.com](http://luxtower.com)

# LUX S10- S11 key benefits



**Compact design**  
**Easy handling**

**Light weight**

**83/84 Kg**



**Easily transportable**  
**by car and vans**

MADE IN  
ITALY



MADE IN  
ITALY

LUXTOWER

[luxtower.com](http://luxtower.com)

# LUX S11 key benefits



**Wind stability**  
**110 km/h**

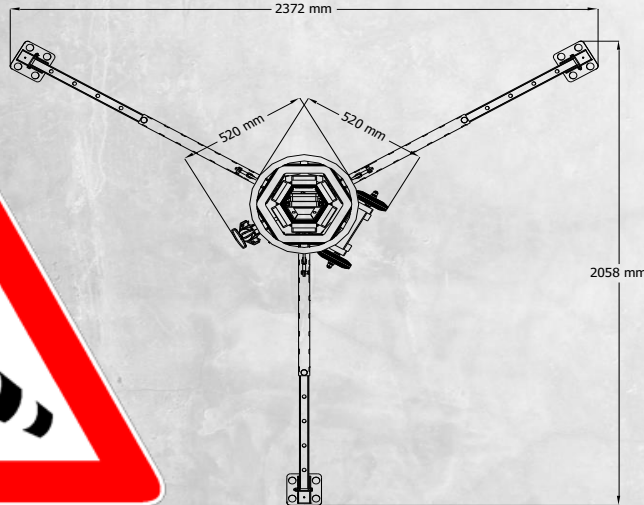
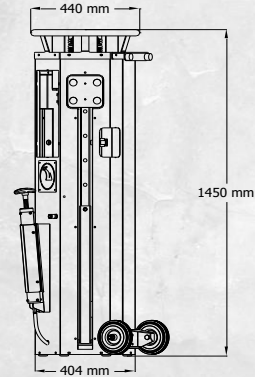

MADE IN  
ITALY

## APPLICATIONS



AIRPORTS



POLICE



SEA PORTS



INDUSTRIES



COSTRUCTIONS



RAILWAYS



EMERGENCY



EVENTS

# LUX S10-S11 key benefits



Total Illuminated Area

**11400 sqm**

**N.6**

25m

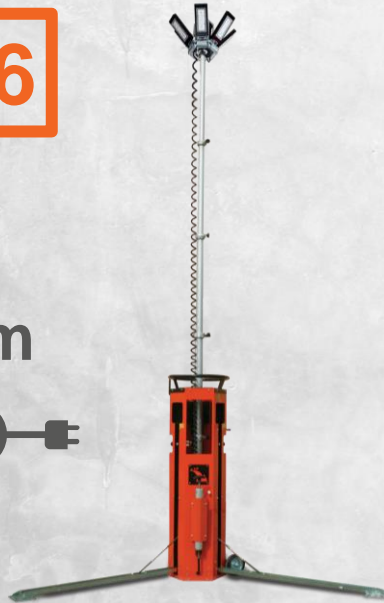

GENERATOR

2 KW

LUX S10

300 W

Total Illuminated Area

**11600 sqm**

**N.4**

25m

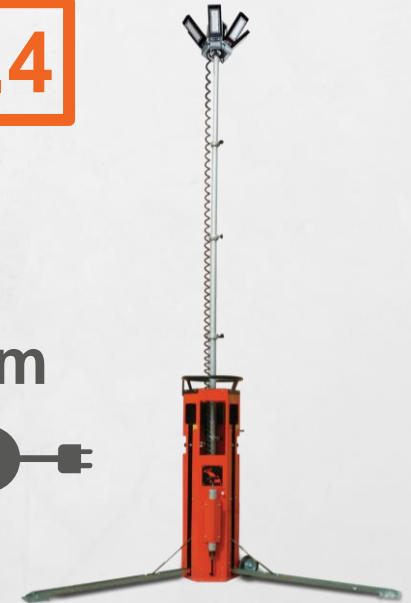

GENERATOR

2 KW

LUX S11

480 W

LUX S10-S11





PASSERELLA OLIMPICA - LINGOTTO  
TORINO

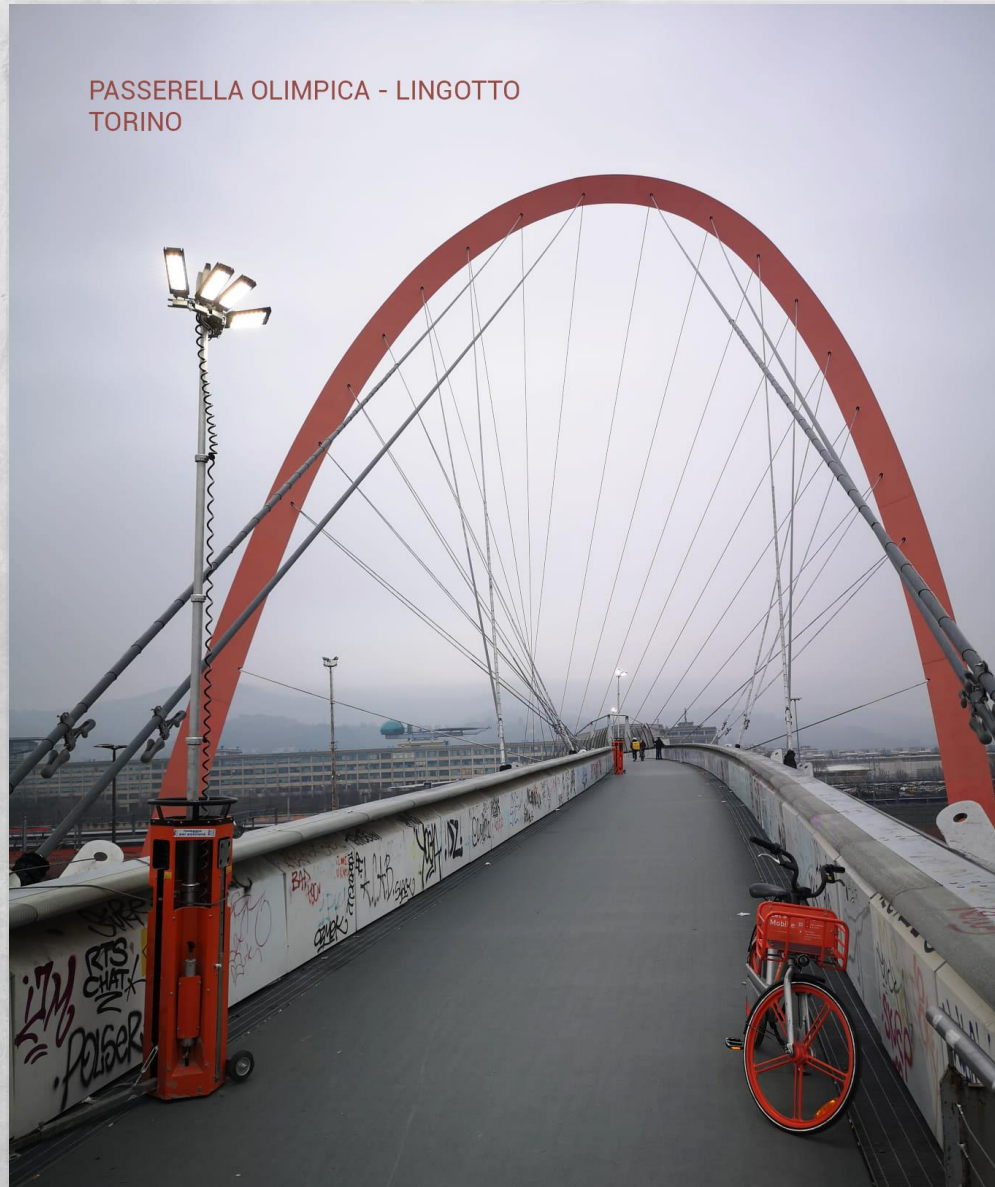



LUX S10-S11



LUX S10



LUX S10



LUXTOWER   
lighting towers

**EXTEND  
THE DAY LIGHT**

**LUXS10**

[luxtower.com](http://luxtower.com)



MADE IN  
ITALY 

LUX S10



**LIGHT** your  
**PASSION**



**LUXTOWER**   
lighting towers

LUXTOWER 

Thank  
you