

## RX 20 Technical Data

### Electric Forklift Truck

---



[RX 20-14C/Li-Ion](#)

[RX 20-16C/Li-Ion](#)

[RX 20-16/Li-Ion](#)

[RX 20-16L/Li-Ion](#)

[RX 20-18/Li-Ion](#)

[RX 20-18L/Li-Ion](#)

[RX 20-20L/Li-Ion](#)

[RX 20-16P/Li-Ion](#)

[RX 20-16PL/Li-Ion](#)

[RX 20-18P/Li-Ion](#)

[RX 20-18PL/Li-Ion](#)

[RX 20-20P/Li-Ion](#)

[RX 20-20PL/Li-Ion](#)

**RX 20 Electric Forklift Truck**  
**Electrifying**

This specification sheet, which conforms to VDI guideline 2198, provides the technical values for the standard equipment only. Different tyres, other masts, additional equipment etc. may produce different figures.



				STILL	STILL	STILL	STILL	STILL	STILL	STILL	
Distinguishing marks	1.1	Manufacturer									
	1.2	Manufacturer's type designation		<b>RX 20-14C/Li-Ion</b>	<b>RX 20-16C/Li-Ion</b>	<b>RX 20-16/Li-Ion</b>	<b>RX 20-16L/Li-Ion</b>	<b>RX 20-18/Li-Ion</b>	<b>RX 20-18L/Li-Ion</b>	<b>RX 20-20L/Li-Ion</b>	
	1.2.1	Manufacturer type number		6219	6220	6221	6222	6223	6224	6225	
	1.3	Drive		Electric	Electric	Electric	Electric	Electric	Electric	Electric	
	1.4	Operation		Seated	Seated	Seated	Seated	Seated	Seated	Seated	
	1.5	Capacity/load	Q	kg	1400	1600	1600	1600	1800	2000	
	1.6	Load centre	c	mm	500	500	500	500	500	500	
	1.8	Load distance	x	mm	374	374	374	374	374	388	
	1.9	Wheel base	y	mm	1319	1319	1409	1517	1409	1517	
Weights	2.1	Service weight (incl. battery)		kg	2926	3125	3057	3127	3231	3486	
	2.2	Axle load, laden	front/rear	kg	3826/500	4160/565	4112/545	4133/594	4440/590	4450/769	
	2.3	Axle load, unladen	front/rear	kg	1498/1428	1500/1625	1520/1537	1611/1516	1524/1707	1612/1806	
Wheels/chassis	3.1	Tyres			Superelastic	Superelastic	Superelastic	Superelastic	Superelastic	Superelastic	
	3.2	Tyre size	front		180/70-8	180/70-8	180/70-8	180/70-8	200/50-10	200/50-10	
	3.3	Tyre size	rear		125/75-8	125/75-8	125/75-8	125/75-8	140/55-9	140/55-9	
	3.5	Number of wheels (x = driven)	front/rear		2x/2	2x/2	2x/2	2x/2	2x/2	2x/2	
	3.6	Track width	front/rear	b <sub>10</sub> /b <sub>11</sub>	mm	932/168	932/168	932/168	932/168	942/172	942/172
	4.1	Angle of mast/fork carriage	forwards/backwards	α/β	°	5/6	5/6	5/6	5/6	5/6	5/6
Dimensions	4.2	Height of mast	when lowered	h <sub>1</sub>	mm	2160	2160	2160	2160	2160	
	4.3	Free lift		h <sub>2</sub>	mm	150	150	150	150	150	
	4.4	Lift <sup>1</sup>		h <sub>3</sub>	mm	3180	3180	3180	3180	3180	
	4.5	Height of mast	when raised	h <sub>4</sub>	mm	3742	3742	3742	3742	3742	
	4.7	Height over overhead guard (low variant)		h <sub>6</sub>	mm	2035 (1949)	2035 (1949)	2035 (1949)	2035 (1949)	2035 (1949)	
	4.8	Seat height/standing height		h <sub>7</sub>	mm	1058	1058	1058	1058	1058	
	4.12	Coupling height		h <sub>10</sub>	mm	473	473	473	473	473	
	4.19	Total length		l <sub>1</sub>	mm	2661	2661	2744	2852	2852	
	4.20	Length including fork backs		l <sub>2</sub>	mm	1861	1861	1944	2052	2052	
	4.21	Total width		b <sub>1</sub>	mm	1099	1099	1099	1149	1149	
	4.22	Depth of prongs		s	mm	40	40	40	40	40	
	4.22.1	Width of prongs		e	mm	80	80	80	80	80	
	4.22.2	Length of prongs		l	mm	800	800	800	800	800	
	4.23	Fork carriage DIN 15173, class/form A, B				ISO II A	ISO II A	ISO II A	ISO II A	ISO II A	
	4.24	Fork carriage width		b <sub>3</sub>	mm	980	980	980	980	980	
	4.31	Ground clearance under mast		m <sub>1</sub>	mm	≥90	≥90	≥90	≥90	≥90	
	4.32	Ground clearance, centre of wheel base		m <sub>2</sub>	mm	114	114	114	114	114	
	4.33	Working aisle width with 1000 x 1200 pallet crossways <sup>2,3</sup>		A <sub>st</sub>	mm	3186	3186	3269	3377	3269	
	4.34	Working aisle width with 800 x 1200 pallet lengthways <sup>2,3</sup>		A <sub>st</sub>	mm	3311	3311	3394	3502	3394	
	4.35	Turning radius		W <sub>a</sub>	mm	1487	1487	1570	1678	1570	
4.36	Smallest pivot point distance		b <sub>13</sub>	mm	-	-	-	-	-		
Performance data	5.1	Driving speed (Blue-Q/Normal/Sprint)	with load	km/h	16/16/20	16/16/20	16/16/20	16/16/20	16/16/20	16/16/20	
	5.1.1	Driving speed (Blue-Q/Normal/Sprint)	without load	km/h	16/16/20	16/16/20	16/16/20	16/16/20	16/16/20	16/16/20	
	5.2	Lifting speed	with load	m/s	0.54	0.53	0.53	0.53	0.52	0.45	
	5.2.1	Lifting speed	without load	m/s	0.75	0.75	0.75	0.75	0.75	0.63	
	5.3	Lowering speed	with/without load	m/s	0.5/0.5	0.51/0.5	0.51/0.5	0.51/0.5	0.52/0.5	0.48/0.41	
	5.5	Drawbar pull <sup>4</sup>	with/without load	N	5100/5100	5100/5200	5100/5200	5100/5200	4900/5100	4800/5000	
	5.6	Max. drawbar pull <sup>4</sup>	with/without load	N	12300/7700	12300/7700	12300/7900	12300/8500	12000/7900	12000/8500	
	5.7	Gradeability <sup>4</sup>	with/without load	%	20.4/24	18.6/24	18.6/24	18.6/24	18.6/24	15/18.1	
	5.8	Max. gradeability <sup>4</sup>	with/without load	%	30.3/27.9	27.6/26	28/27.4	27.4/28.7	25.1/26	25.3/28.3	
	5.9	Acceleration time/15 m (Blue-Q/Normal/Sprint)	with load	s	5.7/5.4/5.1	5.7/5.4/5.1	5.7/5.4/5.1	5.7/5.4/5.1	5.8/5.5/5.2	5.8/5.5/5.3	
5.9.1	Acceleration time/15 m (Blue-Q/Normal/Sprint)	without load	s	5.4/5.1/4.8	5.4/5.1/4.8	5.4/5.1/4.8	5.4/5.1/4.8	5.4/5.1/4.8	5.4/5.1/4.8		
5.10	Service brake				Electric/mechanical	Electric/mechanical	Electric/mechanical	Electric/mechanical	Electric/mechanical		
Electric motor	6.1	Drive motor, rating S2 60 min		kW	2x6.5	2x6.5	2x6.5	2x6.5	2x6.5	2x6.5	
	6.2	Lifting motor, output at S3 15%		kW	11	11	11	11	11	11	
	6.3	Battery according to DIN 43531/35/36 A, B, C, no			DIN 43531 B	DIN 43531 B	DIN 43531 A (B)	DIN 43531 A	DIN 43531 A (B)	DIN 43531 A	
	6.4	Battery voltage	U	V	48	48	48	48	48	48	
	6.4.1	Battery capacity	K <sub>5</sub>	Ah	625	625	625	750	625	750	
	6.5	Battery weight		kg	856	856	855	1013	855	1013	
	6.6	Energy consumption in accordance with EN 16796		kWh/h	3.3	3.8	3.7	3.7	4.1	4.3	
	6.7	Turnover performance		t/h	116	135	131	133	141	149	
6.8	Energy consumption at indicated turnover performance		kWh/h	5.1	5.7	5.5	5.6	5.8	6.0		
Other	10.1	Working pressure for attachments		bar	240	240	240	240	240	240	
	10.2	Oil volume for attachments		l/min	26.5	26.5	26.5	26.5	26.5	26.5	
	10.7	Sound level at driver's ear		dB(A)	<66	<66	<66	<66	<66	<66	
	10.7.1	Human vibrations: acceleration in accordance with EN 13059		m/s <sup>2</sup>	<0.6	<0.6	<0.6	<0.6	<0.6	<0.6	
10.8	Trailer coupling, item/DIN type			Bolt	Bolt	Bolt	Bolt	Bolt	Bolt		

<sup>1</sup> The specified nominal lift includes the tyre deflection and tyre diameter tolerances

<sup>2</sup> Fork overhang not included

<sup>3</sup> For telescopic, HiLo and triplex mast

<sup>4</sup> For the complete forklift truck system

RX 20 Electric Forklift Truck  
Electrifying

This specification sheet, which conforms to VDI guideline 2198, provides the technical values for the standard equipment only.  
Different tyres, other masts, additional equipment etc. may produce different figures.



				STILL	STILL	STILL	STILL	STILL	STILL	
Distinguishing marks	1.1	Manufacturer								
	1.2	Manufacturer's type designation		<b>RX 20-16P/Li-Ion</b>	<b>RX 20-16PL/Li-Ion</b>	<b>RX 20-18P/Li-Ion</b>	<b>RX 20-18PL/Li-Ion</b>	<b>RX 20-20P/Li-Ion</b>	<b>RX 20-20PL/Li-Ion</b>	
	1.2.1	Manufacturer type number		6226	6227	6228	6229	6230	6231	
	1.3	Drive		Electric	Electric	Electric	Electric	Electric	Electric	
	1.4	Operation		Seated	Seated	Seated	Seated	Seated	Seated	
	1.5	Capacity/load	Q	kg	1600	1600	1800	1800	2000	
	1.6	Load centre	c	mm	500	500	500	500	500	
	1.8	Load distance	x	mm	374	374	374	374	388	
	1.9	Wheel base	y	mm	1429	1537	1429	1537	1429	
Weights	2.1	Service weight (incl. battery)		kg	3018	3178	3254	3178	3474	
	2.2	Axle load, laden	front/rear	kg	4098/520	4121/657	4439/616	4435/543	4858/616	
	2.3	Axle load, unladen	front/rear	kg	1520/1498	1612/1567	1538/1717	1612/1567	1616/1858	
Wheels/chassis	3.1	Tyres			Superelastic	Superelastic	Superelastic	Superelastic	Superelastic	
	3.2	Tyre size	front		180/70-8	180/70-8	200/50-10	200/50-10	200/50-10	
	3.3	Tyre size	rear		150/75-8	150/75-8	150/75-8	150/75-8	150/75-8	
	3.5	Number of wheels (x = driven)	front/rear		2 x/2	2 x/2	2 x/2	2 x/2	2 x/2	
	3.6	Track width	front/rear	b <sub>10</sub> /b <sub>11</sub>	mm	932/807	932/807	942/807	942/807	942/807
	4.1	Angle of mast/fork carriage	forwards/backwards	α/β	°	5/6	5/6	5/6	5/6	5/6
Dimensions	4.2	Height of mast	when lowered	h <sub>1</sub>	mm	2160	2160	2160	2160	
	4.3	Free lift		h <sub>2</sub>	mm	150	150	150	150	
	4.4	Lift <sup>1</sup>		h <sub>3</sub>	mm	3180	3180	3180	3180	
	4.5	Height of mast	when raised	h <sub>4</sub>	mm	3742	3742	3742	3742	
	4.7	Height over overhead guard (low variant)		h <sub>6</sub>	mm	2035 (1949)	2035 (1949)	2035 (1949)	2035 (1949)	
	4.8	Seat height/standing height		h <sub>7</sub>	mm	1058	1058	1058	1058	
	4.12	Coupling height		h <sub>10</sub>	mm	537	537	537	537	
	4.19	Total length		l <sub>1</sub>	mm	2837	2945	2837	2945	
	4.20	Length including fork backs		l <sub>2</sub>	mm	2037	2145	2037	2145	
	4.21	Total width		b <sub>1</sub>	mm	1099	1099	1149	1149	
	4.22	Depth of prongs		s	mm	40	40	40	40	
	4.22.1	Width of prongs		e	mm	80	80	80	80	
	4.22.2	Length of prongs		l	mm	800	800	800	800	
	4.23	Fork carriage DIN 15173, class/form A, B				ISO II A	ISO II A	ISO II A	ISO II A	
	4.24	Fork carriage width		b <sub>3</sub>	mm	980	980	980	980	
	4.31	Ground clearance under mast		m <sub>1</sub>	mm	≥90	≥90	≥90	≥90	
	4.32	Ground clearance, centre of wheel base		m <sub>2</sub>	mm	114	114	114	114	
	4.33	Working aisle width with 1000 x 1200 pallet crossways <sup>2,3</sup>		A <sub>st</sub>	mm	3362	3470	3362	3470	
	4.34	Working aisle width with 800 x 1200 pallet lengthways <sup>2,3</sup>		A <sub>st</sub>	mm	3487	3595	3487	3595	
	Performance data	4.35	Turning radius		W <sub>a</sub>	mm	1663	1771	1663	1771
4.36		Smallest pivot point distance		b <sub>13</sub>	mm	-	-	-	-	
5.1		Driving speed (Blue-Q/Normal/Sprint)	with load		km/h	16/16/20	16/16/20	16/16/20	16/16/20	
5.1.1		Driving speed (Blue-Q/Normal/Sprint)	without load		km/h	16/16/20	16/16/20	16/16/20	16/16/20	
5.2		Lifting speed	with load		m/s	0.53	0.53	0.52	0.45	
5.2.1		Lifting speed	without load		m/s	0.75	0.75	0.75	0.63	
5.3		Lowering speed	with/without load		m/s	0.51/0.5	0.51/0.5	0.52/0.5	0.48/0.41	
5.5		Drawbar pull <sup>4</sup>	with/without load		N	5000/5100	5000/5100	4800/5000	4800/5000	
5.6		Max. drawbar pull <sup>4</sup>	with/without load		N	12300/7900	12300/8500	11900/8000	12000/8500	
5.7		Gradeability <sup>4</sup>	with/without load		%	18.6/24	18.6/24	18.6/24	15/18.1	
Electric motor	5.8	Max. gradeability <sup>4</sup>	with/without load		%	27.8/27.8	27.6/28.9	24.8/26	25.4/28.6	
	5.9	Acceleration time/15 m (Blue-Q/Normal/Sprint)	with load		s	5.7/5.4/5.1	5.7/5.4/5.1	5.8/5.5/5.2	5.8/5.5/5.3	
	5.9.1	Acceleration time/15 m (Blue-Q/Normal/Sprint)	without load		s	5.4/5.1/4.8	5.4/5.1/4.8	5.4/5.1/4.8	5.4/5.1/4.8	
	5.10	Service brake				Electric/mechanical	Electric/mechanical	Electric/mechanical	Electric/mechanical	
	6.1	Drive motor, rating S2 60 min			kW	2x6.5	2x6.5	2x6.5	2x6.5	
	6.2	Lifting motor, output at S3 15 %			kW	11	11	11	11	
	6.3	Battery according to DIN 43531/35/36 A, B, C, no				DIN 43531 A (B)	DIN 43531 A	DIN 43531 A (B)	DIN 43531 A	
	6.4	Battery voltage	U	V		48	48	48	48	
	6.4.1	Battery capacity	K <sub>5</sub>	Ah		625	750	625	750	
	6.5	Battery weight		kg		855	1013	855	1013	
Other	6.6	Energy consumption in accordance with EN 16796		kWh/h		3.6	3.8	4.1	4.5	
	6.7	Turnover performance		t/h		129	135	142	155	
	6.8	Energy consumption at indicated turnover performance		kWh/h		5.5	5.7	5.8	6.2	
	10.1	Working pressure for attachments		bar		240	240	240	240	
	10.2	Oil volume for attachments		l/min		26.5	26.5	26.5	26.5	
	10.7	Sound pressure level L <sub>paZ</sub> (operator's position)		dB(A)		<66	<66	<65	<66	
	10.7.1	Human vibrations: acceleration in accordance with EN 13059		m/s <sup>2</sup>		<0.6	<0.6	<0.7	<0.6	
	10.8	Trailer coupling, item/DIN type				Bolt	Bolt	Bolt	Bolt	

<sup>1</sup> The specified nominal lift includes the tyre deflection and tyre diameter tolerances

<sup>2</sup> Fork overhang not included

<sup>3</sup> For telescopic, HiLo and triplex mast

<sup>4</sup> For the complete forklift truck system

RX 20 Electric Forklift Truck  
 Technical Drawings

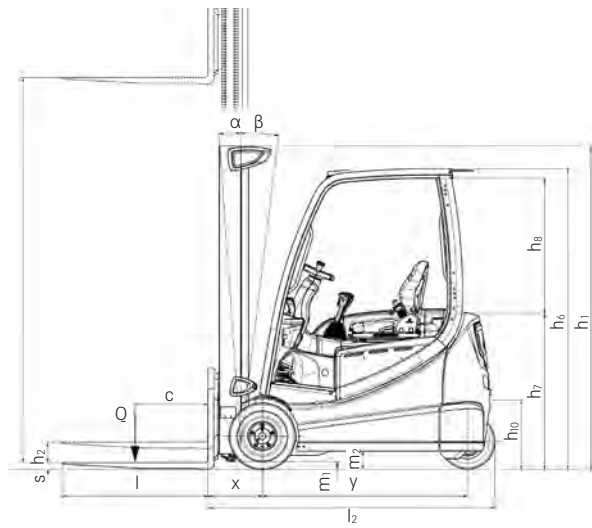

3-wheel side view

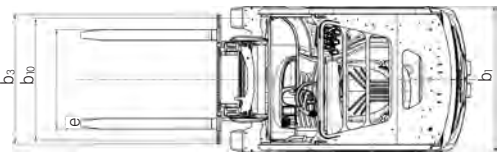

3-wheel top view

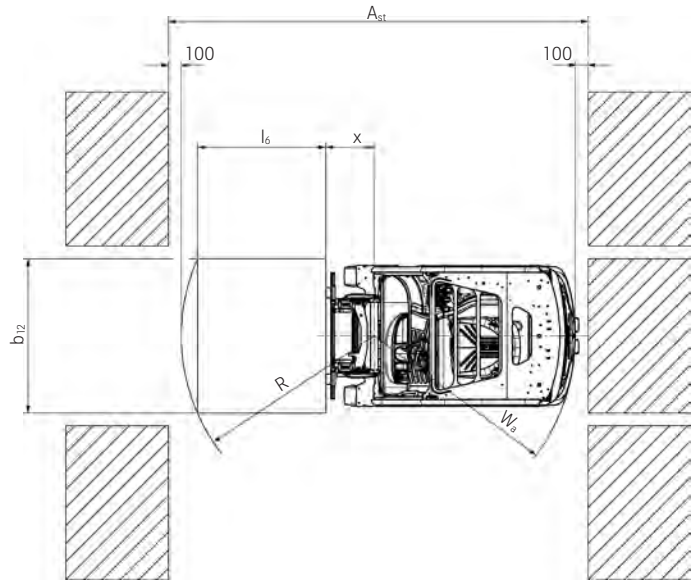

3-wheel top view

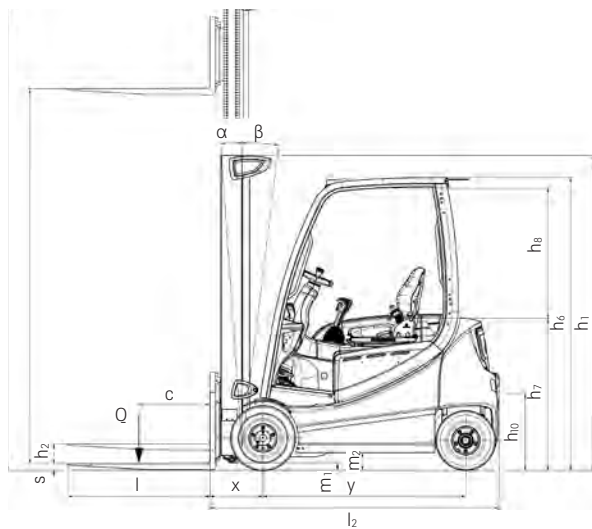

4-wheel side view

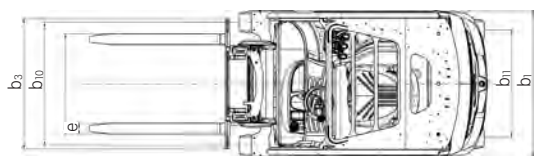

4-wheel top view

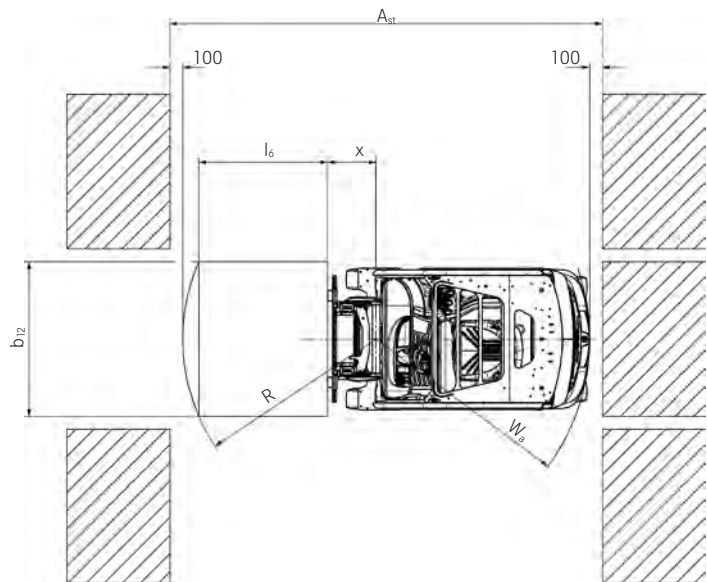

4-wheel top view



RX 20 Electric Forklift Truck  
Electrifying



RX 20 Electric Forklift Truck  
Mast Tables



RX 20-14C	Telescopic mast												NiHo mast						Triplex mast													
	Nominal lift	h <sub>3</sub>	mm	2680	2780	2980	3180	3480	3880	4180	4680	5380	2860	2960	3160	3360	3560	3960	4170	4320	4620	4920	5220	5370	5620	6070	6820	7870				
Height	h <sub>1</sub>	mm	1910	1960	2060	2160	2310	2510	2660	2910	3260	1910	1960	2060	2160	2260	2460	1910	1960	2060	2160	2260	2310	2460	2610	2860	3210					
Free lift	h <sub>2</sub>	mm	150	150	150	150	150	150	150	150	150	1365	1415	1515	1615	1715	1915	1366	1416	1516	1616	1716	1766	1916	2066	2316	2666					
Maximum height	h <sub>4</sub>	mm	3242	3342	3542	3742	4042	4442	4742	5242	5942	3417	3517	3717	3917	4117	4517	4734	4884	5184	5484	5784	5934	6184	6634	7384	8434					
Angle of mast	forwards/backwards	α/β	5/6																													
Fork lock-in position centre-centre		mm	216/368/445/521/673/760																													
Tyres	rear		125/75-8(15x41/2-8)												125/75-8 (15x41/2-8)						125/75-8 (15x41/2 - 8)											
Tyres	front		180/70-8 (18x7-8)												200/50-10						180/70-8 (18x7-8)						200/50-10					
Track	front/rear	mm	932/168												990						932/168						990					
Maximum width	b <sub>1</sub>	mm	1099												1188						1099						1099					

RX 20-16 RX 20-16C, RX 20-16L RX 20-16P, RX 20-16PL	Telescopic mast												NiHo mast						Triplex mast													
	Nominal lift	h <sub>3</sub>	mm	2680	2780	2980	3180	3480	3880	4180	4680	5380	2860	2960	3160	3360	3560	3960	4170	4320	4620	4920	5220	5620	6070	6820	7870					
Height	h <sub>1</sub>	mm	1910	1960	2060	2160	2310	2510	2660	2910	3260	1910	1960	2060	2160	2260	2460	1910	1960	2060	2160	2260	2460	2610	2860	3210						
Free lift	h <sub>2</sub>	mm	150	150	150	150	150	150	150	150	150	1261	1311	1411	1511	1611	1811	1312	1362	1462	1562	1662	1862	2012	2262	2612						
Maximum height	h <sub>4</sub>	mm	3315	3415	3615	3815	4115	4515	4815	5315	6015	3471	3571	3771	3971	4171	4571	4788	4938	5238	5538	5838	6238	6688	7438	8488						
Angle of mast	forwards/backwards	α/β	5/6																													
Fork lock-in position centre-centre		mm	216/368/445/521/673/760																													
Tyres	rear		125/75-8 (15x41/2-8)												125/75-8 (15x41/2-8)						125/75-8 (15x41/2-8)											
Tyres	front		180/70-8 (18x7-8)												200/50-10						180/70-8 (18x7-8)						200/50-10					
Track	front/rear	mm	932/168												990						932/168						990					
Maximum width	b <sub>1</sub>	mm	1099												1188						1099						1149					
Tyres	rear		150/75-8												150/75-8						150/75-8											
Tyres	front		180/70-8 (18x7-8)												200/50-10						180/70-8 (18x7-8)						200/50-10					
Track	front/rear	mm	932/807												990						932/807						990					
Maximum width	b <sub>1</sub>	mm	1099												1188						1099						1188					

RX 20-18 RX 20-18L RX 20-18P, RX 20-18PL	Telescopic mast												NiHo mast						Triplex mast													
	Nominal lift	h <sub>3</sub>	mm	2680	2780	2980	3180	3480	3880	4180	4680	5380	2780	2880	3080	3280	3480	3880	4020	4170	4470	4770	5070	5470	5920	6670	7720					
Height	h <sub>1</sub>	mm	1910	1960	2060	2160	2310	2510	2660	2910	3260	1910	1960	2060	2160	2260	2460	1910	1960	2060	2160	2260	2460	2610	2860	3210						
Free lift	h <sub>2</sub>	mm	150	150	150	150	150	150	150	150	150	1261	1311	1411	1511	1611	1811	1262	1312	1412	1512	1612	1812	1962	2212	2562						
Maximum height	h <sub>4</sub>	mm	3315	3415	3615	3815	4115	4515	4815	5315	6015	3443	3543	3743	3943	4143	4543	4688	4838	5138	5438	5738	6138	6588	7338	8388						
Angle of mast	forwards/backwards	α/β	5/6																													
Fork lock-in position centre-centre		mm	216/368/445/521/673/760																													
Tyres	rear		140/55-9												140/55-9						140/55-9											
Tyres	front		200/50-10												200/50-10						200/50-10											
Track	front/rear	mm	942/172												990						942/172						990					
Maximum width	b <sub>1</sub>	mm	1149												1188						1149						1188					
Tyres	rear		150/75-8												150/75-8						150/75-8											
Tyres	front		200/50-10												200/50-10						200/50-10											
Track	front/rear	mm	942/807												990						942/807						990					
Maximum width	b <sub>1</sub>	mm	1149												1188						1149						1188					

RX 20-20 RX 20-20L RX 20-20P, RX 20-20PL	Telescopic mast												NiHo mast						Triplex mast													
	Nominal lift	h <sub>3</sub>	mm	2650	2750	2950	3150	3450	3850	4150	4650	5350	2770	2870	3070	3270	3470	3870	4030	4180	4480	4780	5080	5680	6130	6880	7930					
Height	h <sub>1</sub>	mm	1910	1960	2060	2160	2310	2510	2660	2910	3260	1910	1960	2060	2160	2260	2460	1910	1960	2060	2160	2260	2460	2610	2860	3210						
Free lift	h <sub>2</sub>	mm	150	150	150	150	150	150	150	150	150	1366	1416	1516	1616	1716	1916	1366	1416	1516	1616	1716	1916	2066	2316	2666						
Maximum height	h <sub>4</sub>	mm	3214	3314	3514	3714	4014	4414	4714	5214	5914	3334	3434	3634	3834	4034	4434	4594	4744	5044	5344	5644	6044	6694	7444	8494						
Angle of mast	forwards/backwards	α/β	5/6																													
Fork lock-in position centre-centre		mm	216/368/445/521/673/760																													
Tyres	rear		140/55-9												140/55-9						140/55-9											
Tyres	front		200/50-10												200/50-10						200/50-10											
Track	front/rear	mm	942/172												990						942/172						990					
Maximum width	b <sub>1</sub>	mm	1149												1188						1149						1188					
Tyres	rear		150/75-8												150/75-8						150/75-8											
Tyres	front		200/50-10												200/50-10						200/50-10											
Track	front/rear	mm	942/807												990						942/807						990					
Maximum width	b <sub>1</sub>	mm	1149												1188						1149						1188					

# RX 20 Electric Forklift Truck

## Basic Load Capacities

**RX 20-14C Duplex/NiHo mast single SE tyres**

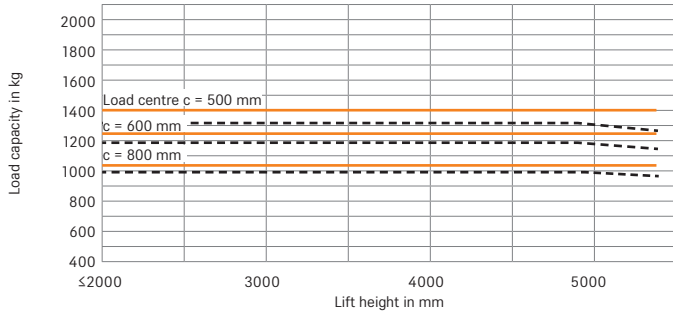

**RX 20-14C Triplex mast single SE tyres**

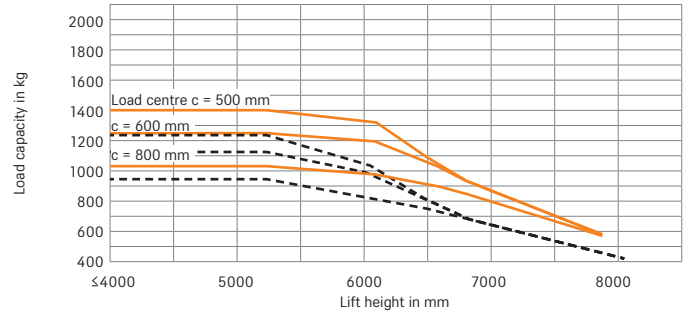

**RX 20-16C Duplex/NiHo mast single SE tyres**

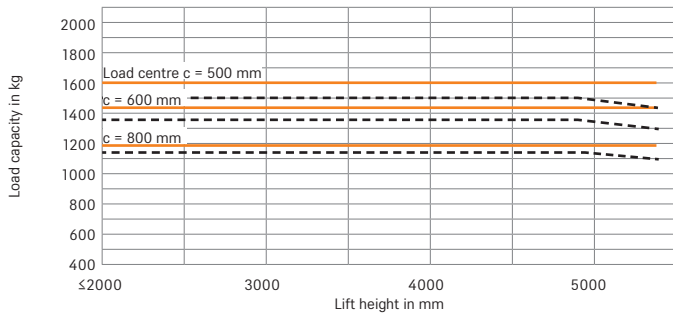

**RX 20-16C Triplex mast single SE tyres**

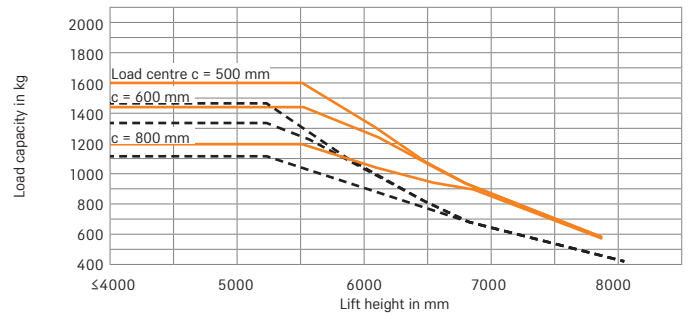

**RX 20-16/RX 20-16P Duplex/NiHo mast single SE tyres**

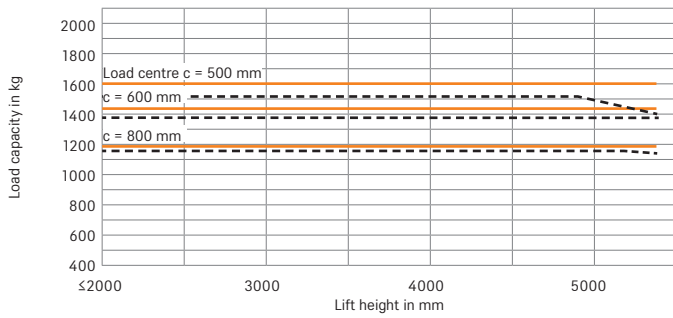

**RX 20-16/RX 20-16P Triplex mast single SE tyres**

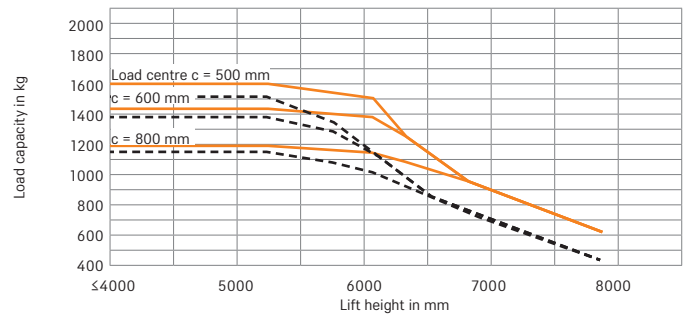

**RX 20-16L/RX 20-16PL Duplex/NiHo mast single SE tyres**

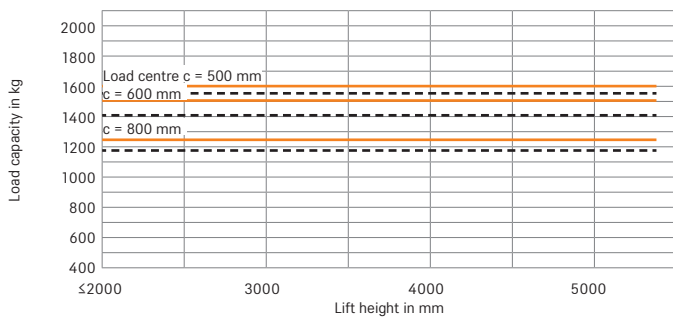

**RX 20-16L/RX 20-16PL Triplex mast single SE tyres**

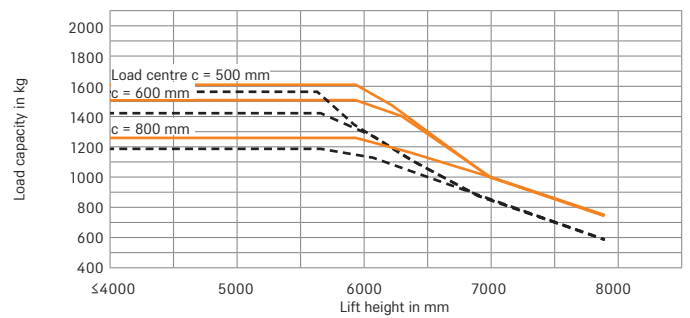

——— with standard forks   
 - - - - - with integrated side shifter and standard forks  
 The listed values may vary depending on the forklift equipment



# RX 20 Electric Forklift Truck

## Basic Load Capacities

**RX 20-18/RX 20-18P Duplex/NiHo mast single SE tyres**

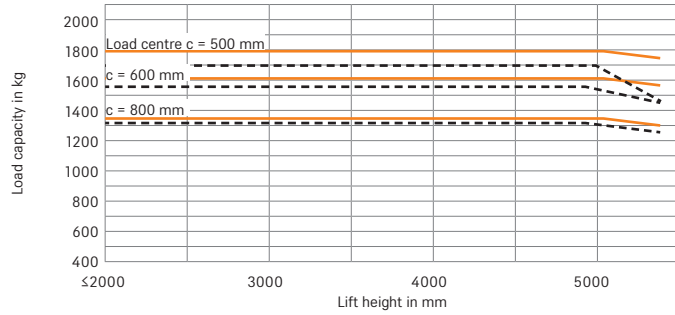

**RX 20-18/RX 20-18P Triplex mast single SE tyres**

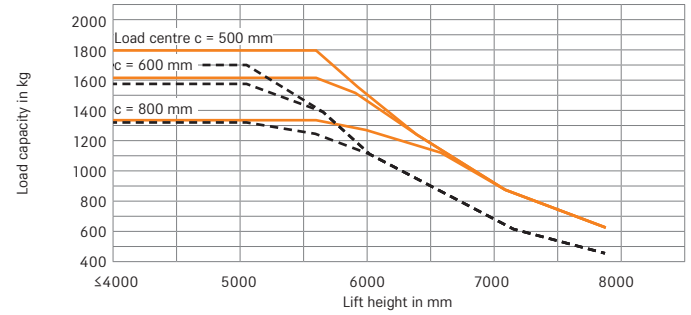

**RX 20-18L Duplex/NiHo mast single SE tyres**

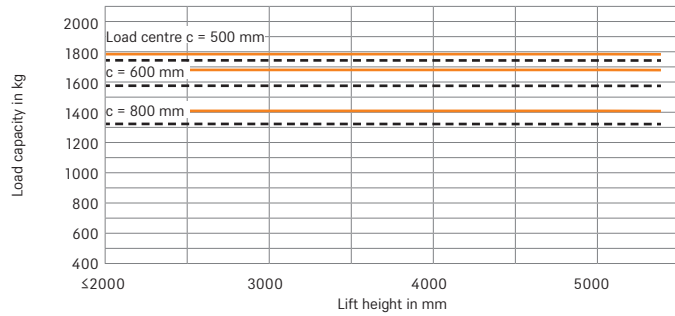

**RX 20-18L Triplex mast single SE tyres**

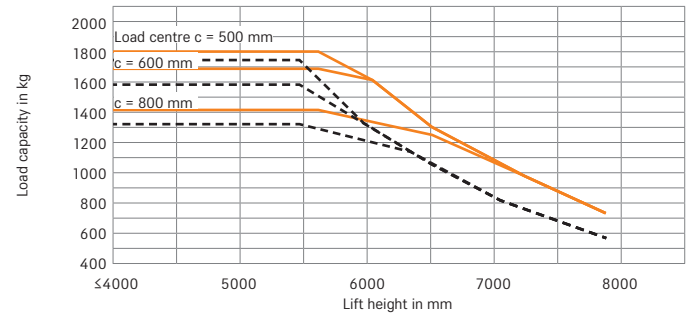

**RX 20-18PL Duplex/NiHo mast single SE tyres**

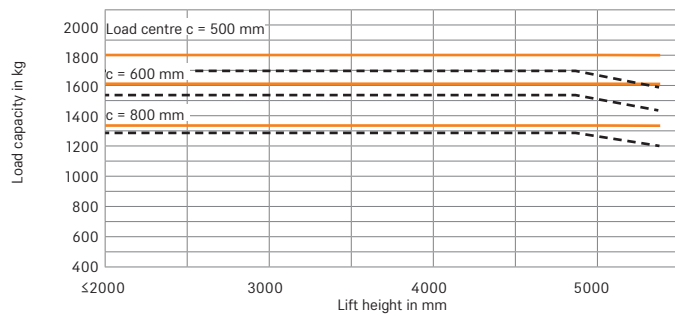

**RX 20-18PL Triplex mast single SE tyres**

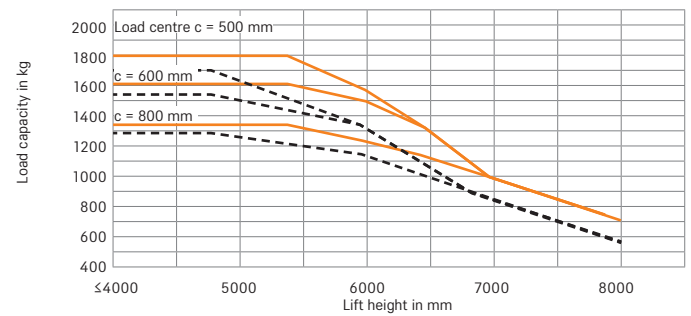

**RX 20-20P Duplex/NiHo mast single SE tyres**

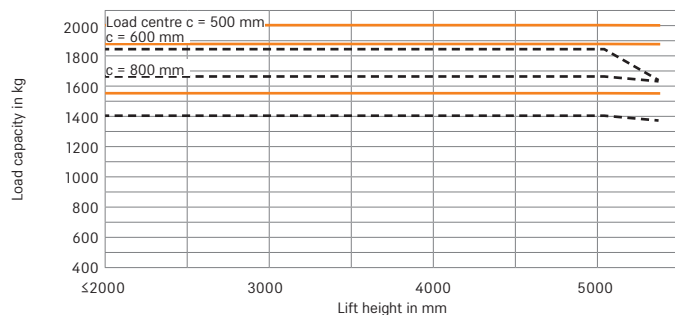

**RX 20-20P Triplex mast single SE tyres**

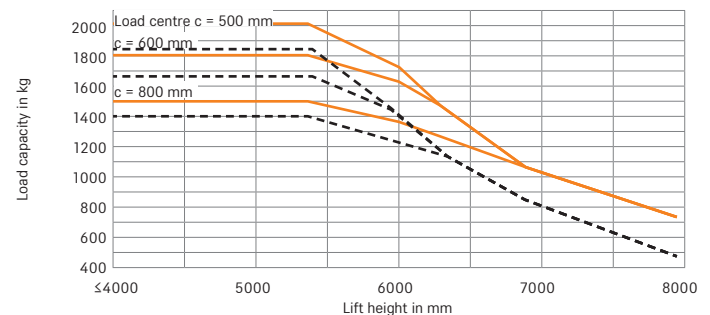

**RX 20-20L/RX 20-20PL Duplex/NiHo mast single SE tyres**

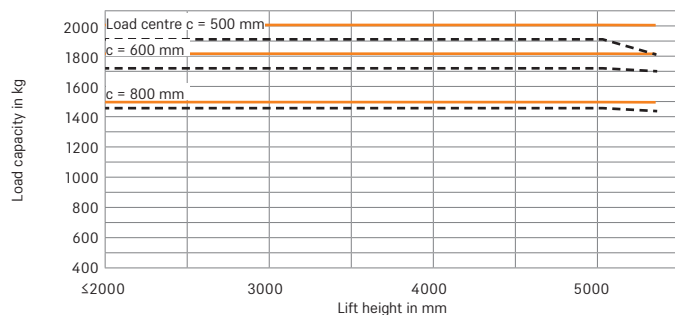

**RX 20-20L/RX 20-20PL Triplex mast single SE tyres**

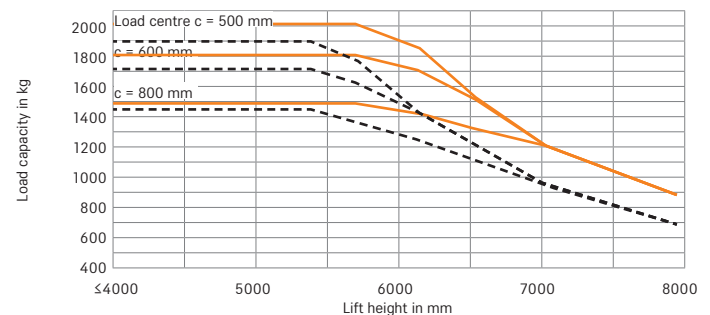

— with standard forks   
 - - - - - with integrated side shifter and standard forks  
 The listed values may vary depending on the forklift equipment



RX 20 Electric Forklift Truck  
Detailed Photos



Four-wheel version with fully enclosed driver's cabin for outdoor use



Optimal view of fork tips when loading HGVs

RX 20 Electric Forklift Truck  
Detailed Photos



View upwards



Enhanced visibility thanks to panoramic armoured glass pane



Spacious access and footwell



Optional onboard charger for decentralized charging without battery change



Workspace with display and control units, Joystick 4Plus and heating



Work fast and safely thanks to excellent visibility over and past the Easy View mast



Wide seat with fabric cover and right armrest



Swivel seat handle with optional horn operation for ergonomic reverse driving



Swivel seat for comfortable reversing



Battery change with electric pallet truck

Gradients

	Gradient	Maximum distance in m													
		RX 20-14C	RX 20-16C	RX 20-16	RX 20-16L	RX 20-16P	RX 20-16PL	RX 20-18	RX 20-18L	RX 20-18P	RX 20-18PL	RX 20-20L	RX 20-20P	RX 20-20PL	
With nominal load	22.9%	1860	1501	1502	1501	1517	1509	1423	1431	1431	1439	1079	1054	1079	
	18.6%	3350	3380	3458	3456	3559	3442	3284	3300	3300	3300	2611	2546	2611	
	1.2%	7770	7531	7663	7489	7741	7533	7322	7346	7269	7582	6857	6870	6883	
	6.1%	14683	13751	13761	13450	14070	13637	13320	13318	13164	13320	12186	12187	12500	
Without load	25.1%	3421	3221	3285	3213	3325	3213	3151	3134	3137	3215	3027	3196	3027	
	18.1%	8230	8037	8165	7884	8244	8017	7876	7762	7768	7949	5632	5610	5642	
	9.6%	15316	14432	15066	14402	14937	14402	13969	13958	13969	14183	13570	13483	13601	
	4.7%	20000	20000	20000	20000	20000	20000	20000	20000	20000	20000	20000	20000	20000	

Dry rough concrete = coefficient of friction 0.80  
Battery: standard as per data sheet; speed is variable

Maximum distance that can be driven in 60 minutes.  
Example: With a load of 1,800 kg and a gradient of 18.6%, an RX 20-18P can drive a distance of 330 m up to ten times in an hour.



## RX 20 Electric Forklift Truck Electrifying

---

Highest handling performance of its class

Highest range with one battery charge

Best all-round visibility for high work safety

High agility and precise manoeuvrability



The STILL RX 20 offers more of everything: more power, more dynamism and more availability. The latest generation of STILL's top-selling electric forklift truck is the best RX 20 that STILL ever developed. There is the new safety and communication centre for safety and handling performance (STILL Easy Control): The driver can activate performance functions depending on the application and receives all important safety information at a glance. With the safest and quickest battery change and the largest Li-Ion battery capacity of its class, the RX 20 can be used around the clock. Dynamic acceleration, 20 km/h maximum speed, precise manoeuvrability – with these trademark features, the RX 20 achieves the highest ever handling performance in the load range from 1.4 to 2 tonnes.

When it comes to narrow aisle widths in heavy-duty two- or three-shift applications, the RX 20 really shows its strengths. This includes beverages and hardware stores, the receipt and dispatch of goods in trade and logistics applications, or production supply in the mechanical engineering and automotive industries. Equipped with Li-Ion technology, the RX 20 Li-Ion is number one for availability. Just 30 minutes of charging extend the usage time by several operating hours. The compact electric forklift truck gets its energy from Li-Ion batteries which are suitable for cold storage. When in operation, an intelligent electronics system monitors every battery cell in real time. Safety, performance and availability are what make the RX 20 Li-Ion a uniquely efficient conveyor of goods.

### The 'Simply Efficient' factors: Performance attributes as a measure of economic efficiency

---



#### Simply easy

---

- Intuitive handling: standard, easy-to-use operating concept across the whole RX product line
- Efficiency-enhancing: easy entry into a highly ergonomic driver's cab
- STILL Easy Control on-board computer: all relevant information at a glance and performance functions just a click away
- Ultra-fast: easy-to-operate lateral battery change
- Systematic safety: optional pre-shift check on the display to help with the daily safety inspection
- Safety for every application: wide range of additional equipment options – from a direction indicator on the display to the Safety Light 4Plus safety lighting, as well Curve Speed Control for automatic speed reduction when cornering



#### Simply powerful

---

- Intralogistics powerhouse: highest handling performance of its class
- Performance boost: sprint mode for peak performance at the touch of a button
- Optimum energy efficiency: exceptionally long range with each battery charge
- Intelligent support: traction control and other assistance functions
- Ready at all times: optional STILL lithium-ion technology for maximum availability



#### Simply safe

---

- Safe and precise handling: high-precision hydraulics and agile driving dynamics
- Safe entry: large handle, anti-slip rubber mat and wide step
- Optimal panoramic view: slim mast and extra-large windows



#### Simply flexible

---

- Customised control options: multi-lever, mini-lever, Fingertip or Joystick 4Plus
- Adjustable performance dynamics: parameters such as driving and lifting speed can be adjusted to personal preferences at the touch of a button
- Operating power tailored to your specifications: wide variety of equipment options for every application
- Flexible, decentralised charging: Onboard Charger enables simple, fast and location-independent charging processes



#### Simply connected

---

- Optimum networking: optional interface for integration into fleet management software such as STILL neXXt fleet
- Controlled use: optional access control protects against incorrect operation

# RX20 Electric Forklift Truck

## Equipment Variants



	RX20-14C RX20-16C	RX20-16 RX20-18	RX20-16L RX20-18L RX20-20L	RX20-16P RX20-18P RX20-20P	RX20-16PL RX20-18PL RX20-20PL	
Operator's cab	Weather-protected, canvas or full cab with interior lighting	○	○	○	○	
	Lowered cab	○	○	○	○	
	Raised operator's position for a better view of the load	-	-	○	-	○
	Drive-in overhead guard	○	○	○	○	○
	Tinted front and rear windscreen, roof window made of laminated safety glass or Makrolon, plus windscreen wiper/washer system	○	○	○	○	○
	Non-splintering cabin glazing and lighting	○	○	○	○	○
	Panorama roof or adjustable roof window for instant cabin ventilation	○	○	○	○	○
	Front and upper sun blind	○	○	○	○	○
	Storage box above the counterweight	○	○	○	○	○
	Built-in storage and cup holder	●	●	●	●	●
	Dual-pedal control	○	○	○	○	○
	Splash-proof operating unit featuring display, function buttons and menu navigation	●	●	●	●	●
	Pad with clipboard (removable)	○	○	○	○	○
	MSG 65 Grammer seat with leatherette cover	●	●	●	●	●
	Seat with textile cover, air suspension, with lumbar support, adjustable back extension, heated seat, document pocket on the backrest	○	○	○	○	○
	Swivel seat which can be rotated to the right or horizontal spring plate for operator's seat to minimise human vibrations	○	○	○	○	○
	Grab handle on front and back of protective roof	●	●	●	●	●
	Grab handle on back of protective roof with horn	○	○	○	○	○
	Radio/MP3 player with USB connection and Bluetooth	○	○	○	○	○
	Clamp mount for mobile phone, mounted adjustably on the overhead guard bar	○	○	○	○	○
High-performance 2000 W electric heating incl. defrosting blaster	○	○	○	○	○	
Mast	Telescopic or triplex free view mast	○	○	○	○	
	Load backrest	○	○	○	○	
	Hydraulic accumulator in the lifting cylinder to attenuate pressure peaks in the hydraulic system	○	○	○	○	○
	Bellows protect the tilt cylinder from dust and moisture	○	○	○	○	○
	Vertical positioning of the mast at the push of a button, tilt angle display and cushioned lowering in the tilt end positions	○	○	○	○	○
	Fork wear protection	○	○	○	○	○
	Lift height sensor and display, lift height pre-selection, lift stop, electrical reach damping and end cushioning	○	○	○	○	○
Tyres	Single tyres, superelastic, SIT system	●	●	●	●	
	Single tyres, superelastic, natural coloured, SIT system	○	○	○	○	
Hydraulics	Multi-lever operation	●	●	●	●	
	Armrest with mini-levers, Fingertip or Joystick 4Plus	○	○	○	○	
	Cold store variant, hydraulic oil suitable for low temperature ranges	○	○	○	○	
Drives	Shake function for easy tipping of containers	○	○	○	○	
	3 fixed and 2 freely configurable driving programs, Blue-Q energy saving mode, sprint mode for optimal handling performance at the push of a button	●	●	●	●	
	Display showing energy consumption and remaining driving time based on current charge	●	●	●	●	
	Lithium-ion battery exchangeable 1:1	●	●	●	●	
Brake	On-board charger or quick charging access	○	○	○	○	
	Mechanical parking brake	●	●	●	●	
Safety	Automatic parking brake	○	○	○	○	
	Protective grille roof	○	○	○	○	
	EasyBelt restraint system for quick and safe fastening and unfastening	○	○	○	○	
	Sauermann restraint system model Duo HRS-E or IWS restraint system with strap opening on the left	○	○	○	○	
	Headlights and LED lighting performance	○	○	○	○	
	LED floodlights on the mast	○	○	○	○	
	STILL Safety Light 4Plus warning device	○	○	○	○	
	Safety Zone Light: Warning light bars to the left and right of the truck	○	○	○	○	
	Adjustable speed limiter	○	○	○	○	
	Front, rear and all-round view camera systems	○	○	○	○	
	Curve Speed Control	●	●	●	●	
	Load measuring	○	○	○	○	
	Panoramic mirror	○	○	○	○	
	Ceiling sensor: Speed regulation for indoor and outdoor areas	○	○	○	○	
	Speed reduction when fork carriage is raised	○	○	○	○	
	Dynamic Load Control 1, Dynamic Load Control 2	○	○	○	○	
	FleetManager: Access authorisation, shock detection, reports	○	○	○	○	
	Overload detection	○	○	○	○	
	Pre-shift check in the display: Guided safety check before the truck can be operated	○	○	○	○	
	Intelligent seat belt control with logic check	●	●	●	●	
Rockinger trailer coupling	○	○	○	○		
Road traffic version	○	○	○	○		
Explosion-proof variant	○	○	○	○		

● Standard ○ Option — Not available



STILL GmbH  
Berzeliusstr. 10  
22113 Hamburg  
Germany  
Tel.: +49 40 73 39 20 00  
Fax: +49 40 73 39 20 01  
info@still.de

**For further information please visit**  
**[www.still.eu](http://www.still.eu)**

STILL is certified in the following areas: Quality management, occupational safety, environmental protection and energy management.



**first in intralogistics**