

# Model 4069LE

SCISSOR LIFTS



## MORE ECONOMIC

- Electric power for zero emissions and near-silent running indoors.

## MORE PRODUCTIVE

- Boost efficiency with direct electric drive.

## MORE ACCESS

- Enjoy enhanced versatility with true multi-terrain capability.

## SMART DESIGN

- Enjoy industry leading upcycles so you can work longer with higher productivity.



## Standard Features

- 0.91 m roll-out deck extension
- Fold-down handrails
- Self-closing gate
- Removable platform console box
- Lanyard attach points
- Full proportional drive joystick control with integral thumb steer switch
- Proportional lift/lower speed control
- Joystick enable for lift and drive
- Load sensing system
- Two speed drive selection
- Two Wheel Direct Electric Drive
- 8 x 6V 370 A/hr deep cycle batteries
- Automatic traction control
- Programmable "Personality" settings
- On-board self-diagnostic testing
- Detachable battery compartments
- 20 amp automatic battery charger
- Automatic rear wheel brakes
- Sculptured steel hoods
- 3 degree tilt alarm and indicator light
- Steel scissor guards
- Oscillating rear axle
- Lifting/tie down lugs
- Lubrication free scissor arm bushings
- Scissor maintenance prop
- AC cable to platform
- Ground control selector switch with key lock
- Battery condition indicator
- Hour meter
- Horn
- Manual descent pull cable

## Standard Specifications

- Tyres (non-marking)
- Drive Motors
- Batteries
- Charger (120/240V - 50/60HZ)
- Hydraulic System
- 240/55-17.5
- Dual Electric Traction
- 8 x 6V 370 A/hr
- 20 Amp SCR Automatic
- 32 L

## Accessories & Options

- Hydraulic levelling jacks
- 13mm air line to platform
- 390 A/hr AGM Batteries
- All motion alarm
- Descent alarm
- Alarm package <sup>1</sup>
- Platform work-lights
- Amber strobe light
- Euro Plug & Socket
- Synthetic Biodegradable Hydraulic Oil
- Special paint colour

<sup>1</sup> Includes all-motion alarm and amber strobe light.

# Model 4069LE

## SCISSOR LIFTS

### Performance

- Working Height 14.19 m
- Platform Height – Elevated 12.19 m
  - A. Stowed Height 2.80 m
  - B. Platform Railing Height 1.10 m
  - C. Stowed Height (Rails Folded) 2.04 m
  - D. Platform Size (W X L) 1.65 m x 2.92 m
  - E. Deck Extension 0.91 m
  - F. Overall Width 1.75 m
  - G. Overall Length 3.07 m
  - H. Wheelbase 2.32 m
  - I. Ground Clearance 0.20 m
- Platform Capacity 360 kg
- Capacity on Deck Extension 120 kg
- Lift/Lower Time 54/50 sec.
- Maximum Drive Height 9.14 m
- Machine weight 5,300 kg
- Maximum Ground Bearing Pressure 4.3 kg/cm<sup>2</sup>
- Drive Speed – Lowered 4.8 km/h
- Gradeability 35%
- Turning Radius – Inside 2.29 m
- Turning Radius – Outside 4.88 m



### Dimensions

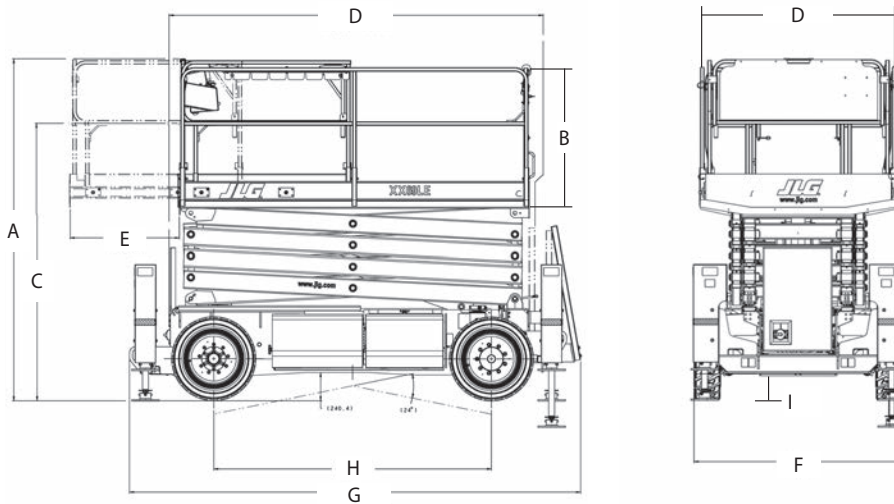

### IMPORTANT

JLG is continually researching and developing products and reserves the right to make modifications without prior notice. All data in this document is indicative. Certain options or country standards will increase weight. Specifications may change to meet country standards or with the addition of optional equipment.

Due to continuous product improvements, JLG Industries reserves the right to make specification and/or equipment changes without prior notification.



### JLG EMEA BV

Polaris Avenue 63  
2132 JH Hoofddorp  
The Netherlands  
Tel: +31 (0)23 565 5665  
Fax: +31 (0)23 557 3750  
[www.jlg.com](http://www.jlg.com)

An Oshkosh Corporation Company